

# Chelsea® 270 Series

Powershift Hydraulic 6-Bolt



## Overview:

Quality knows quality, that's why Allison and Aisin chose Chelsea to join their engineers in developing P.T.O.s specifically for their transmissions. The versatile 270 Series is a Powershift P.T.O. This provides the operator a smooth engagement with no gear clashing which helps extend the life of the P.T.O. and transmission gears. It is available in four speed ratios, six shift options and eleven output types including Chelsea's popular 360° rotatable flange. The 270 Series features an option for protecting your driven equipment, this is our Electronic Overspeed Control (E.O.C.). This feature prevents the driver from going down the road with the P.T.O. engaged preventing cavitations on hydraulic equipment. Another popular feature available for the 270 Series is the internal self adjusting shaft brake. This prevents shaft rotation on devices such as water or transfer pumps when the P.T.O. is disengaged.

- LP Gas Trucks
- Water Trucks
- Fire and Rescue
- Aerial Devices
- Dump Truck & Trailers
- Snow and Ice Removal



## Product Features and Benefits:

- Electric-over-hydraulic shifting
- Internal self adjusting shaft brake option (patent #7159701)
- P.T.O./Dump Pump combo valve shift option available
- Intermittent Torque Rating of 250-300 Lbs. ft.
- Four (4) speed ratios
- Eleven (11) output options
- Six (6) shift options
- Electronic Overspeed Control
- No Backlash to set
- Two Year Warranty

## Contact Information:

**Transdiesel Australia Pty Ltd**  
77 McKellar Way, Epping, Victoria, Australia 3076  
ph: (03) 9305 0800  
[www.transdiesel.com.au](http://www.transdiesel.com.au)

# 270 SERIES POWER TAKE-OFF SPECIFICATIONS AND TECHNICAL DATA

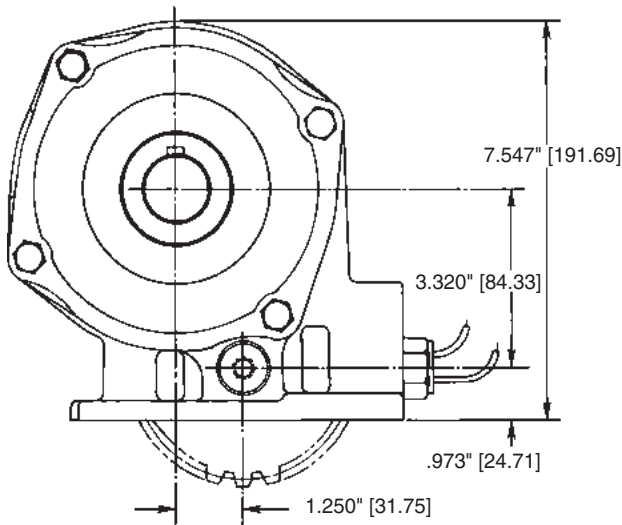
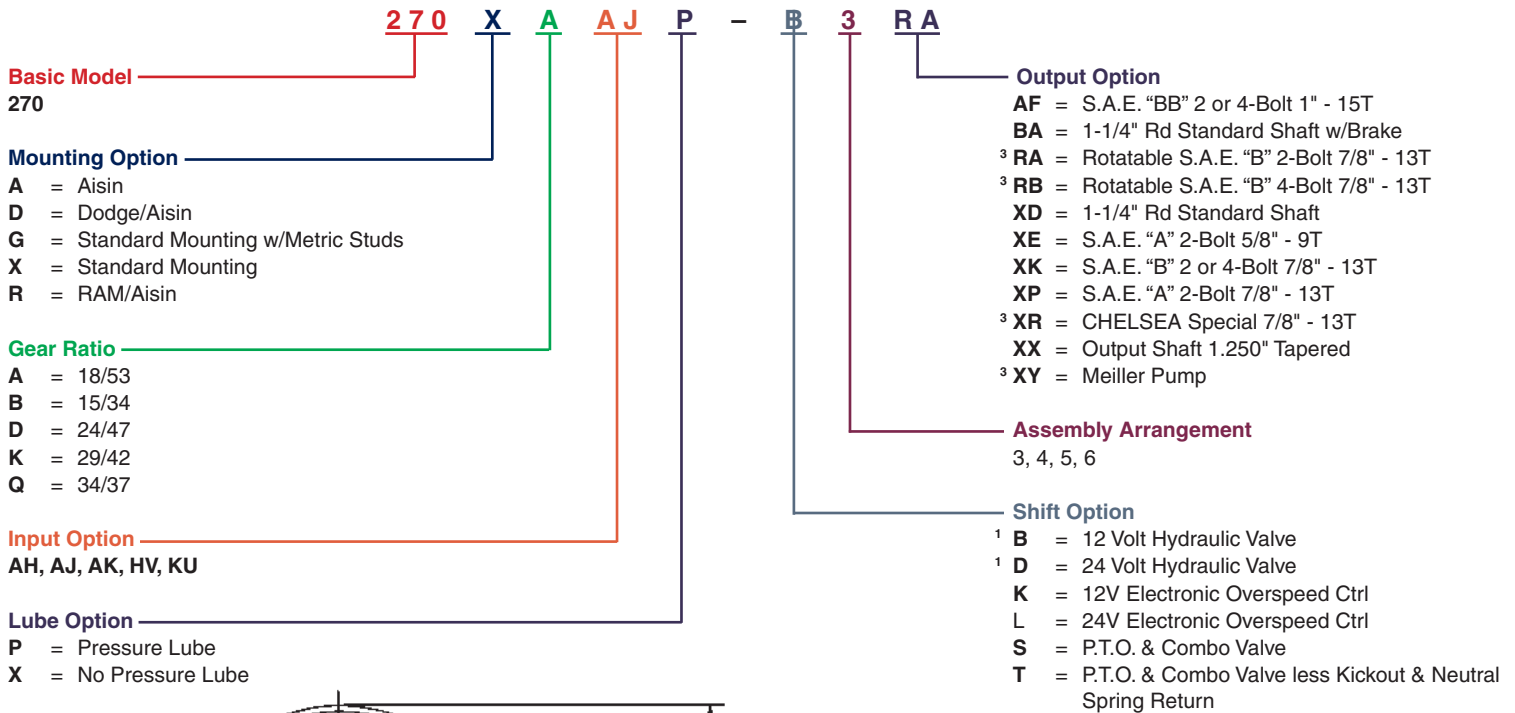

<sup>1</sup> Includes mounting parts  
<sup>3</sup> Available assembly 3 & 5 only

## Specifications Chart

	270*A, B, D & K w/Pressure Lube	270*A, B, D & K w/Standard Lube
Standard Output Shaft Size	1-1/4"	
Intermittent Torque Rating (Lbs. ft.)	300	250
Intermittent Torque Rating (N.m.)	407	339
Horsepower Rating for Intermittent Service		
At 500 R.P.M. of Output Shaft (HP)	29	24
At 1000 R.P.M. of Output Shaft (HP)	57	48
At 500 R.P.M. of Output Shaft (Kw)	21	18
At 1000 R.P.M. of Output Shaft (Kw)	43	36
Approximate Weight:	49 lbs. [22 kg]	

Supercedes HY25-0076-B1/US April 2013 HY25-0076-B1/US September 2014